



## Technical Summary

### Contract for Procurement of Piping and Fittings (IO/14/CFT/9560/ACS – CP/1)

#### Control of modifications

Version	Section(s)	Modification
1.0	All	First issue
2.0	<ul style="list-style-type: none"><li>• Timetable</li><li>• Experience</li></ul>	<ul style="list-style-type: none"><li>• Update of the Timetable</li><li>• Text clarified for the required experience</li></ul>

#### Purpose

The purpose of this call for nomination is to establish a Framework Contract for procurement of piping and fittings required for the ITER project under a centralized procurement.

#### Background

ITER will be the largest and most complex nuclear fusion system yet to be built. Situated in Southern France, adjacent to the French CEA Cadarache site, the ITER facility covers approximately 190 hectares and is designed to study the fusion reaction between hydrogen isotopes, tritium and deuterium.

The ITER Organization will require piping and fittings for the construction of the ITER systems, and those requirements have been identified in the following systems:

- LOT 1: TCWS (Tokamak Cooling Water Systems)
- LOT 2: Vacuum Systems
- LOT 3: Detritiation Systems
- LOT 4: TBMs (Test Blankets Modules)
- LOT 5: Diagnostic Systems
- LOT 6: Type A Radwaste System
- LOT 7: CCWS (Component Cooling Water Systems) and CHWS (Chilled Water Systems)



## **Scope of Work**

The Contractor will be required to supply piping and fittings to the ITER Organization (and Domestic Agencies) under the conditions of the Framework Contract to be signed with the ITER Organization.

The table 1 below represents the preliminary bill of materials of the piping and fittings required for the ITER Organization. Please note that they can be subject to changes. Also it may be possible that some of LOT or part of them might not be under the scope of the Framework Contract. This will be further clarified at the time of the Call for Tender.

The scope of supply includes manufacture, testing, cleaning, packaging and delivery of the pipe and pipework fittings to the ITER site, France.

For the detailed scope of work of each LOT, please refer to Annexes.



LOT No.	Systems	Item	Process	Grade/Material	Size	Schedule or WT (mm)	Amount	Units
1	<b>TCWS</b>	Pipe	Seamless	ASTM A312 GR.TP304L & 316L (low Cobalt < 0.05%)	DN20 to DN350	Sch 40s to 80s	$10 \leq X \leq 15$	km
		Pipe	Seamless	ASTM A312 GR.TP304L & 316L (normal Cobalt < 0.20%)	DN20 to DN350	Sch 40s to 80s	$15 \leq X \leq 20$	km
		Pipe	Welded	ASTM A312 GR.TP304L & 316L (normal Cobalt < 0.20%)	DN400 to DN650	Sch 40s to Sch 80s	$X \leq 5$	km
		Fittings	Seamless or Welded	ASTM A403 Grade WP304L/CR304L & WP316L/CR316L	DN20 to DN650	Sch 40s to 80s	14 000 +/- 20%	Units
		Integrally reinforced branch outlet Fittings	Forged	ASTM A312 GR. TP304L	DN20 to DN650	-	13 500 +/- 20%	Units
2	<b>Vacuum</b>	Pipe	Seamless	ASTM Grade 304L	DN25 to DN300	Sch 10 or Sch 20	$7.5 \leq X \leq 12.5$	km
		Fittings	Seamless	ASTM Grade 304L	DN25 to DN300	Sch 10 or Sch 20	TBD	Units
3	<b>Detritiation</b>	Pipe	Seamless	ASTM Grade 304L	DN25 to DN400	Sch 10 or Sch 40	$10 \leq X \leq 15$	km
		Fittings	Seamless	ASTM Grade 304L	DN25 to DN400	Sch 10 or Sch 40	800 +/- 20%	Units
4	<b>Test Blanket Modules</b>	Pipe	Seamless	ASTM Grade 316L or RCC-MR 1.4404 or 1.4435	DN15 to DN250	Sch 5 to 160	$X \leq 5$	km
		Fittings	Seamless or flat product	ASTM Grade 316L or RCC-MR 1.4404 or 1.4435	DN15 to DN250	Sch 5 to 160	TBD	Units
5	<b>Diagnostics</b>	Pipe	Seamless	Grade 316L or equivalent, Grade 304L or equivalent, or Carbon steel	DN8 to DN200	Sch 10 to 40	$2 \leq X \leq 8$	km
		Fittings	Seamless	Grade 316L or equivalent, Grade 304L or equivalent, or Carbon steel	DN8 to DN200	Sch 10 to 40	TBD	Units



LOT No.	Systems	Item	Process	Grade/Material	Size	Schedule or WT (mm)	Amount	Units
6	<b>Type A RadWaste</b>	Pipe	Seamless	ASTM A312 Grade WP304	DN50	Sch 40	X ≤ 100	mtr
		Fittings	Seamless	ASTM A403 Grade WP304	DN50	Sch 40	TBD	Units
7	<b>CCWS &amp; CHWS</b>	Pipe (Stainless Steel)	Seamless or Welded	ASTM A312 Grade TP304 and ASTM A358 Grade 304L CL	DN25 to DN650	Sch 40	12.5 ≤ X ≤ 17.5	km
		Pipe (Carbon Steel)	Seamless or Welded	ASTM A53 Gr. B and ASTM A672 Gr.B	DN50 to DN600	Sch 40	X ≤ 5	km
		Fittings (Stainless or Carbon)	Seamless or Welded	TBD	TBD	TBD	TBD	Units

<b>Total (round numbers)</b>		
Stainless Pipe	60 ≤ X ≤ 100	km
Carbon Pipe	X ≤ 5	Km
Fittings	30 000 +/- 20%	Units

**Table 1- Preliminary Bill of Materials (subject to change)**



## **Timetable**

The tentative timetable is as follows:

- Call for Nominations July 2014
- Pre-Qualification October 2014
- Call for Tender December 2014
- Tender Submission February 2015
- Award of the Framework Contract March 2015

The ITER Organization may combine Pre-Qualification and Call for Tender at its option.

## **Experience**

The Supplier shall have demonstrable experience in the supply of pipes and fittings for the nuclear industry or for industries using similar standards than the ones used in the nuclear industry.

In particular, the Supplier shall have demonstrable experience in piping and fitting manufacturing conformingly to ASTM A312M and A403M standards.

With regards to the compliancy with the French regulations, the Supplier shall be able to comply with ESP [2] and ESPN [3] French regulations (involving specific requirements on chemical composition and mechanical properties which will be detailed at the Call For Tender stage).

Also, the Supplier and his subcontractors (if any) shall be able to provide Quality Assurance and Supply Chain Management Systems required for manufacturing of nuclear components and shall be able to comply with the French Order of 7th February 2012 establishing the general rules for basic nuclear installations [4].

For this compliancy with French regulations (ESP, ESPN and French Order of 7th February 2012), a capability and not a proven experience will be required at the Pre-Qualification stage. To justify this capability, subcontracting strategies will be accepted.

## **Candidature**

Participation is open to all legal persons participating either individually or in a grouping (consortium) which is established in an ITER Member State. A legal person cannot participate individually or as a consortium partner in more than one application or tender of the same contract. A consortium may be a permanent, legally-established grouping or a grouping, which has been constituted informally for a specific tender procedure. All members of a consortium (i.e. the leader and all other members) are jointly and severally liable to the ITER Organization.

The consortium groupings shall be presented at the pre-qualification stage. The Candidate's composition cannot be modified without the approval of the ITER Organization after the pre-qualification.



Legal entities belonging to the same legal grouping are allowed to participate separately if they are able to demonstrate independent technical and financial capacities. Candidates (individual or consortium) must comply with the selection criteria. The IO reserves the right to disregard duplicated reference projects and may exclude such legal entities from the pre-qualification procedure.

**The candidates shall be nominated for the full scope of work (Lots 1 to 7).**

### References

- [1] ASME B31.3, ASME B16.5, ASME B16.9
- [2] ESP - Equipement Sous Pression- French Decree 99-1046 of 13 December 1999 on Pressure Equipment
- [3] ESPN - Equipement Sous Pression Nucleaire - French Order 2005 December 12<sup>th</sup> for nuclear pressurised equipment (ESPN)
- [4] French Order dated 7 February 2012 relating to the general technical regulations applicable to INB - EN (ITER\_D\_7M2YKF).
- [5] RCC-MR edition 2007

### Annexes

- Annex 1: Summary for LOT 1 - Tokamak Cooling Water System (TCWS)
- Annex 2: Summary for LOT 2 - Vacuum Systems
- Annex 3: Summary for LOT 3 - Detritiation Systems
- Annex 4: Summary for LOT 4 – Test Blanket Modules
- Annex 5: Summary for LOT 5 - Diagnostic Systems
- Annex 6: Summary for LOT 6 - Type A Radwaste System
- Annex 7: Summary for LOT 7 - Component Cooling Water System (CCWS) and Chilled Water System (CHWS)

## Annex 1

### Technical Summary for LOT 1 (TCWS)

#### Purpose

The purpose of this LOT is to procure pipes and fittings for the construction of IO Tokamak Cooling Water System (TCWS). The items to be procured for the TCWS piping and fittings are seamless austenitic stainless steel pipes, welded austenitic stainless steel pipes, seamless and welded austenitic stainless steel butt welding fittings, and austenitic stainless steel integrally reinforced forged branch outlet fittings.

#### Background

The Cooling Water System (CWS) Section has the responsibility to design, procure and construct the TCWS. The TCWS has the following functions:

- To remove the heat load transferred from the Plasma to the Vacuum Vessel and in-vessel components (e.g. Blanket modules, Divertor, and In-Vessel Coils) with pressurised water (up to 156 °C and 4.0 MPa).
- To provide the decay heat cooling.
- To provide hot water (up to 240 °C and 4.4 MPa) and hot nitrogen gas (up to 350 °C 2.0 MPa) for baking of Vacuum Vessel and In-Vessel Components.
- To confine the activated corrosion products and the tritium potentially contained in the water.

In order to complete the construction of the TCWS, IO needs to procure the piping and fittings.

#### Scope of work

The required scope of this LOT will be as follows:

- TCWS seamless austenitic stainless steel pipes
  - ✓ The piping is ESPN class (N2 and N3). Pipes are seamless austenitic stainless steel according to ASTM A312M grade TP304L and TP316L with additional supplementary requirements which will be given in the technical specification at the Call for Tender stage;
  - ✓ Size DN 25 to DN350;
  - ✓ Schedule 40s to 80s.

- TCWS welded austenitic stainless steel pipes
  - ✓ The piping is ESPN class (N2 and N3). Pipes are welded austenitic stainless steel, according to ASTM A312M grade TP304L and TP316L with additional supplementary requirements which will be given in the technical specification at the Call for Tender stage;
  - ✓ Size DN 400 to DN 650;
  - ✓ Schedule 40s to 80s.
  
- TCWS seamless and welded austenitic stainless steel butt welding fittings
  - ✓ The fittings are for the piping ESPN class (N2 and N3). Fittings are seamless and welded austenitic stainless steel, according to ASTM A403 grade WP304L/CR304L and WP316L/CR316L with additional supplementary requirements which will be given in the technical specification at the Call for Tender stage;  
The following is an example of the type of fittings concerned:
    - Elbows,
    - Tees,
    - Reducers,
    - Caps,
    - Branches, etc...;
  - ✓ Schedule 40s to 80s.
  
- TCWS austenitic stainless steel integrally reinforced forged branch outlet fittings
  - ✓ The austenitic stainless steel integrally reinforced forged branch outlet fittings for the TCWS shall comply with the requirements of ASME B31.3 for Category M fluid service and MSS SP-97 with additional supplementary requirements which will be given in the technical specification at the Call for Tender stage.



## Annex 2

### Technical Summary for LOT 2 (Vacuum Systems)

#### Purpose

The purpose of this LOT is to procure pipes and pipework fittings to be used for the construction of ITER IO Vacuum Systems. The items to be procured under the scope of this LOT are stainless steel pipes and pipework fittings.

#### Scope of work

- General Requirements

The Contractor shall supply to the ITER IO vacuum pipes and pipework fittings (tees, elbows, caps, branches etc.) with the following requirements:

- ✓ Seamless stainless steel, AISI grade 304L.
- ✓ Schedules 10 or 20.
- ✓ Sizes DN25 to DN300.

- Code & Regulatory Requirements

Pipe and pipework fittings procured under the scope of this LOT shall perform a confinement function<sup>1</sup>.

As defined in the French Order of 7<sup>th</sup> February 2012 establishing the general rules for basic nuclear installations [4] components which perform a safety function (e.g. provide confinement) are classified as Protection Important Components (PIC) and hence shall satisfy the requirements of the said order.

Pipe and pipework fittings shall comply with ASME B31.3-2010 Category M fluid.

Pipe and pipework fittings shall be supplied with material certification in compliance with EN 10204:2004 type 3.2.

- Vacuum Requirements

Pipe and pipework fittings supplied under the scope of the LOT shall perform a vacuum containment<sup>2</sup> function and shall be subject to requirements pertaining to, for example, cleaning and vacuum leak rate ( $10^{-10}$  Pam<sup>3</sup>/s). These requirements will be explicitly stated in the Technical Specification part of the Call for Tender for the supply of stainless steel vacuum pipe and fittings for the ITER project.

---

<sup>1</sup> Confinement is the term used for the physical enclosure of hazardous substances (e.g. tritium).

<sup>2</sup> Vacuum containment is a term used for vacuum tight boundaries which cope with a pressure differential in either direction. Vacuum containment may also provide vacuum confinement.



## Annex 3

### Technical Summary for LOT 3 (Detritiation Systems)

#### Purpose

The purpose of this LOT is to procure pipes and fittings to be used for the construction of ITER IO Detritiation System (DS).

#### Background

ITER safety system includes the largest and most complex atmosphere detritiation system yet to be built. It consists of piping networks for:

- Tokamak Complex (PBS 32.DT.80),
- Hot Cell Facility (PBS 32.DH.80).

DS has a piping network distributed throughout the Tokamak Complex and Hot Cell Facility. Please refer to Attachment 1 for further details on the system and on the scope of work.

#### Scope of work

Most of the DS components are classified as Protection Important Components under the French Quality Order of 7<sup>th</sup> February 2012. The contractor shall execute the following activities, in compliance with the Technical Specifications for the Detritiation System piping network.

- Procure pipes and fittings according to the IO Technical, based on quantity estimates provided by the IO. All pipes and fittings are in 304L, wall thickness is schedule 10S or 40S;
- Provide the certification of conformity 3.1 in accordance with EN 10204.

**Attachment 1 to Annex 3 (LOT3 – Detritiation System)**

The ITER Detritiation System includes the piping networks for the following:

- Tokamak Complex (PBS 32.DT.80),
- Hot Cell Facility (PBS 32.DH.80).

An overview of the Tokamak Complex DS is given in Figure 1.

DS piping network serves as a ventilation network to transfer room air and other gases containing radioactive contamination to the DS core processing equipment for detritiation prior to release of the gases to the environment. Normal operating conditions are ambient meaning temperatures of 10-35 C and pressures near atmospheric (below 1.5 bar(a)). The DS piping network is all seamless stainless steel 304L schedule 10S or 40S pipes with sizes from DN25 to DN400. Most of the piping network is classified as Protection Important Components and shall be built taking into account seismic load stresses and thermal load stresses due to fire events.

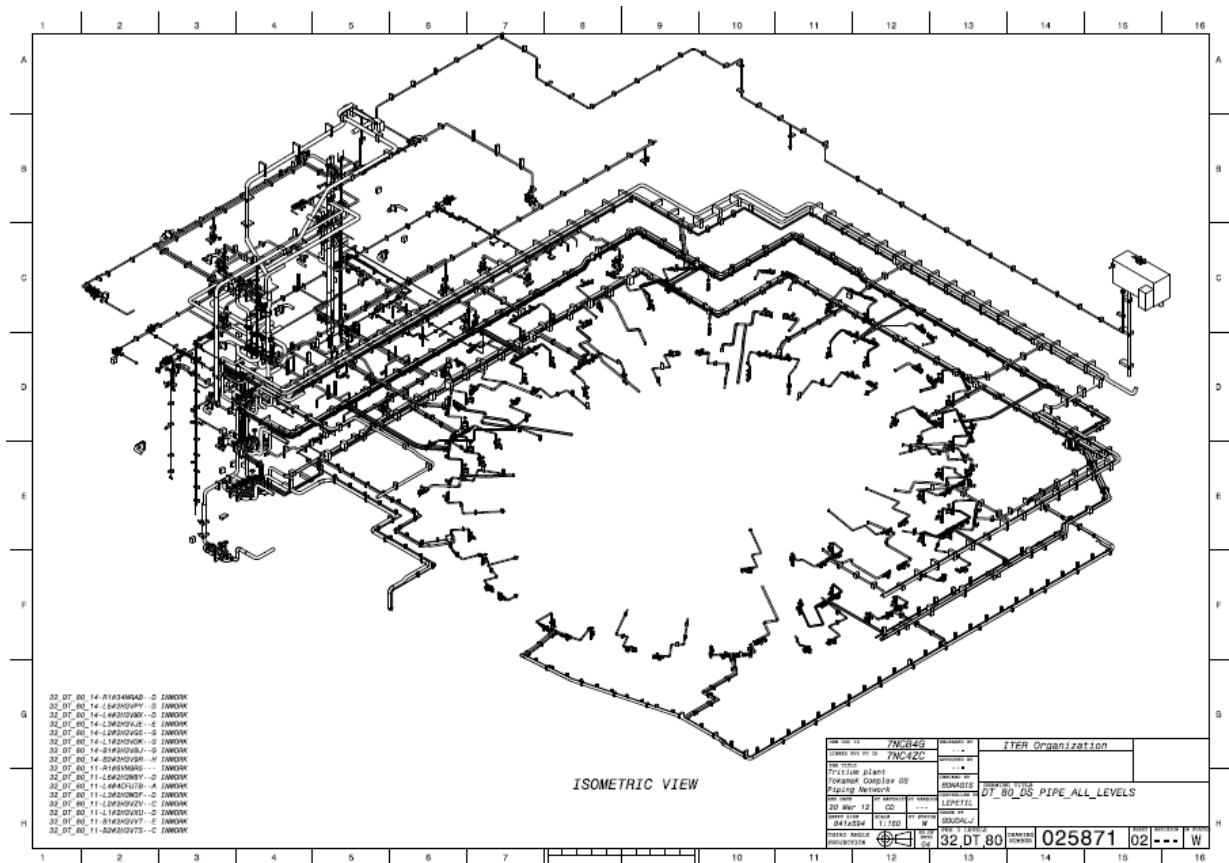

Figure 1 - Overview of ITER Detritiation piping network for Tokamak complex



## **Annex 4**

### **Technical Summary for LOT 4 (TBMs)**

#### **Purpose**

The purpose of LOT is to procure Connection Pipes and Fittings for Test Blanket Modules. Items to be procured under the scope of this LOT are stainless steel pipes and stainless steel fittings and flanges.

#### **Background**

The ITER Test Blanket Modules Program purpose is to test different tritium breeding technologies in fusion reactor, by the mean of six Test Blanket Modules (TBMs).

TBS Connection Pipes (items to be procured) are interconnecting ancillary equipment inside each Test Blanket Module.

#### **Scope of work**

- Generalities

ITER IO requires having a choice to provide TBS Connection Pipes according to ASME [1] or according to RCC-MR [5]. In both cases, TBS Connection Pipes shall be provided in compliance with requirements of ESP [2] and/or ESPN [3]. Selected code and standards will be specified in the technical specification at the Call for Tender stage.



- Items to be procured and required codes and standards

- **Straight Pipes**

	ASME [1]	RCC-MR [5]
Material	Austenitic stainless steel	
Material Grade	gr 316L (UNS 31603)	1.4404 or 1.4435
Specifications * (general requirements, material)	ASME B31.3 (Category M-fluid) ASME SA 312	RCC-MR - RM 3342
Process	Seamless Pipes	
DN	from DN 15 to DN 250	
Schedule	from 5s to 160s	
Maximum allowable pressure**	0- 172 bar	
Maximum allowable temperature**	20 - 550°C	
ESPN class	N2 and N3	
ESP class	SEP, I, II and III	
Other requirements	Order of 7th February 2012 establishing the general rules for basic nuclear installations [4]	

\*Stipulated sections of applicable code refers to other applicable sections of the same code

\*\*given only for information

- **Fittings (Elbows, Reducers, TEE junctions, Y junctions) and Flanges**

	ASME [1]	RCC-MR [5]
Material	Austenitic stainless steel	
Material Grade	gr 316L (UNS 31603)	1.4404 or 1.4435
Specifications * (general requirements, base material, filler material)	ASME B31.3 (Category M-fluid) ASME B16.9 ASME B16.5 ASME SA 403 ASME SA 312 ASME SA 182 ASME SA 240 SFA-5.4 SFA-5.9	RCC-MR - RM 3342 RCC-MR - RM 3332 RCC-MR - RM 3347 RCC-MR - RS 2712 RCC-MR - RS 2711
Process	Base material : Seamless tubular or flat products Manufacturing: welding and forming	
DN	from DN 15 to DN 250	
Schedule	from 5s to 160s	
Maximum allowable pressure**	0 - 172 bar	



Maximum allowable temperature**	20 - 550°C
ESPN [3] class	N2 and N3
ESP [2]class	SEP, I, II and III
Other requirements	Order of 7th February 2012 establishing the general rules for basic nuclear installations [4]

\*Stipulated sections of applicable code refers to other applicable sections of the code

\*\*given only for information

## Annex 5

### Technical Summary for LOT 5 (Diagnostic Systems)

#### Purpose

The purpose of this LOT is to procure pipe and pipework fittings to be used for the construction of ITER IO Diagnostics Systems. The items to be procured under the scope of this LOT are stainless steel pipes and pipework fittings.

#### Background

- Diagnostics in Tokamak building:

Diagnostic systems are required to ensure the operation of ITER throughout all campaigns and will be installed in multiple locations. In particular, many diagnostic systems will be installed in the Upper (10), Equatorial (8) and Lower (3) ports. It is also likely that several diagnostics may be allocated in 4 Upper ports above Neutral Beam Cell. The assembled port plugs and diagnostic racks in the Lower ports themselves, as well as several diagnostics inside port plugs, will require active cooling during operation and will have to be baked before operation.

Figure A1 shows a specific example of the Generic Upper Port Plug with required piping network to be implemented.

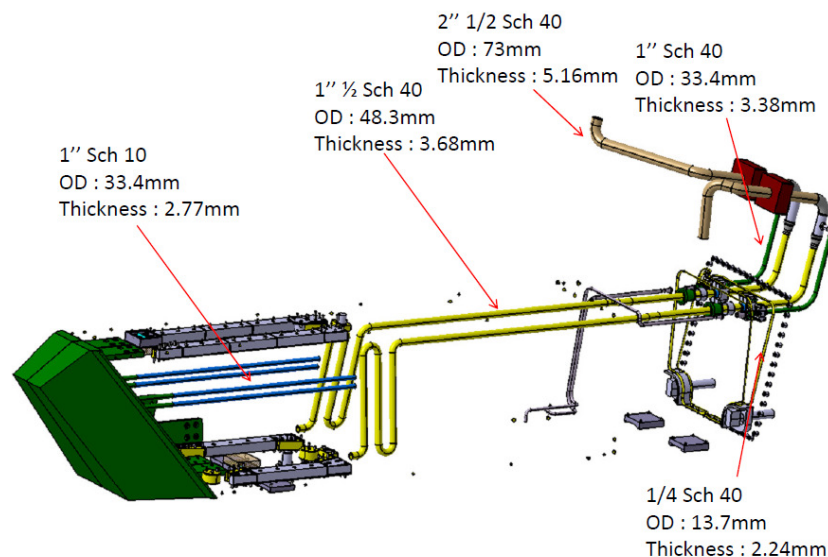
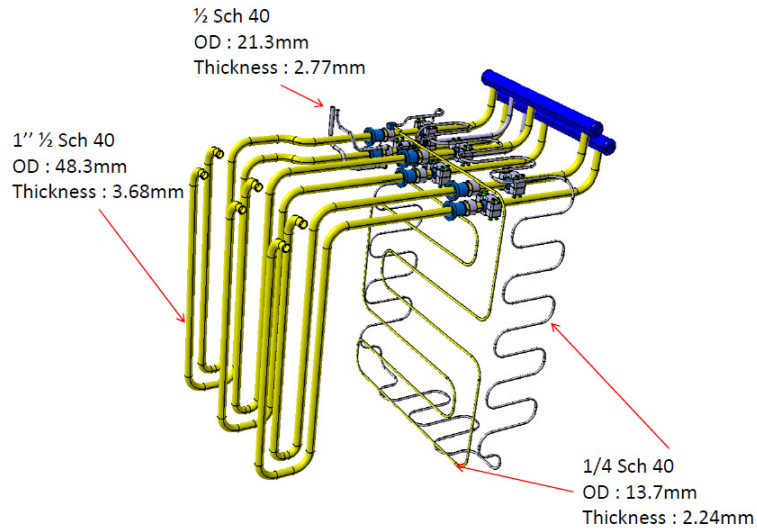

**Fig. A1: View of the Generic Upper Port Plug with water cooling pipes and components.**

A connection pipe for the port plug cooling is defined as a pipe going from the Tokamak cooling water interface to the Diagnostic Shield Module through the port plug closure plate. The diagnostics inside the port plugs may require a separate piping

to be supplied to the individual cooling circuits through the closure plate. For the Lower port diagnostics cooling, the pipes will go through the feedouts next to the Port Closure Plate and along the wall parallel to the Divertor Cooling pipes towards the Diagnostic Racks.

Some details of the Generic Equatorial Port Plug and Lower Port Rack Connection Pipes are given in Fig. A2 and Fig. A3, respectively.



**Fig. A2: View of the Generic Upper Port Plug with water cooling pipes and components.**

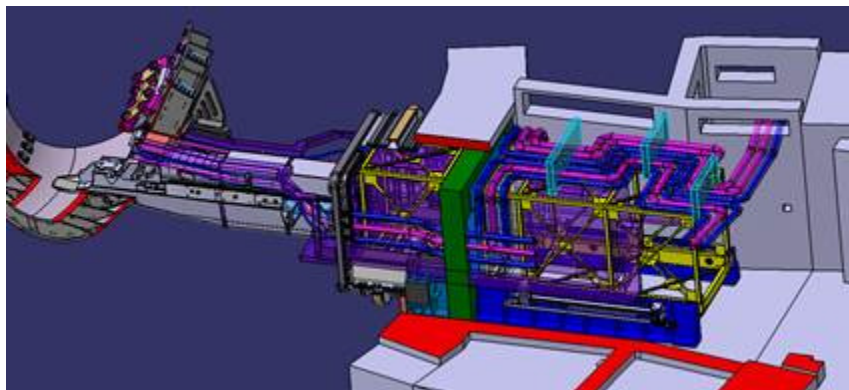

**Fig. A3: Details of Piping network in the typical Diagnostic Lower port.**

In addition to these cooling pipes, various diagnostic components will need connection to the vacuum system and gas supply and additional pipes will be required for these purposes.



- Diagnostics in other buildings:

Other diagnostic components will be placed out of the Tokamak building. In particular many components will be located in the Diagnostic building but also the Assembly Hall will host some of them. Main examples are gyrotrons, fig A4, and laser systems.

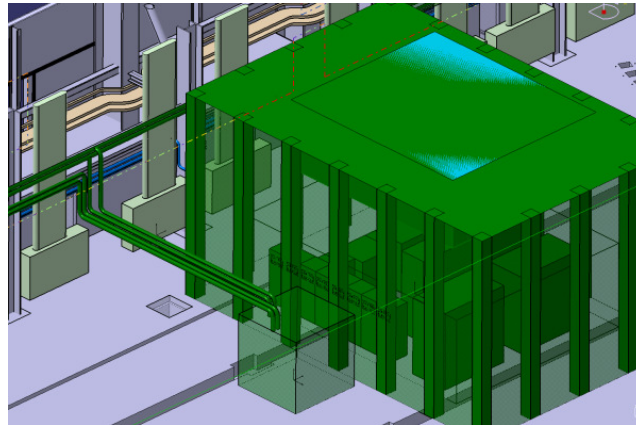

**Fig. A4: Gyrotron placed in Assembly Hall**

### Scope of work

- General Requirements

The Contractor shall supply to the ITER IO diagnostics pipes and pipework fittings (tees, elbows, caps, branches etc.) with the following requirements:

- ✓ The Pipe structural material will be SS-316L or equivalent grade for EN standard will be used for pipes. Piping for components outside the Tokamak building would require other grades (SS-304L, carbon steel);
- ✓ Seamless Pipes;
- ✓ Schedules 10 to 40;
- ✓ Sizes DN 8 to DN 200.

- Code & Regulatory Requirements

The contractor shall execute the activities in compliance with the French Quality Order of 7 February 2012, in compliance with the applicable ESP-ESPN classification and conformity requirements, and under the direct supervision of the selected NB or ANB, where applicable.

Some pipe and pipework fittings procured under the scope of this LOT shall perform a confinement function<sup>3</sup>.

Pipe and pipework fittings shall comply with RCC-MR or equivalent code.

Pipe and pipework fittings shall be supplied with material certification.

---

<sup>3</sup> Confinement is the term used for the physical enclosure of hazardous substances (e.g. tritium).



- Diagnostics requirements

ITER special requirements (i.e. vacuum handbook, materials composition, ferritic content and magnetic permeability etc.) will apply to those pipes used inside the cryostat.

Some of the pipe and pipework fittings supplied under the scope of the LOT shall perform a vacuum containment<sup>4</sup> function and shall be subject to requirements pertaining to, for example, cleaning and vacuum leak rate.

Other important requisites are that the impurities content of the material for piping inside the cryostat are limited (e.g. in particular, the cobalt content will be lower than 0.05%).

These requirements will be explicitly stated in the technical specification which will be issued at the Call for Tender stage.

---

<sup>4</sup> Vacuum containment is a term used for vacuum tight boundaries which cope with a pressure differential in either direction. Vacuum containment may also provide vacuum confinement.



## Annex 6

# Technical Summary for LOT 6 (Type A Radwaste System)

### Purpose

The purpose of this LOT is to procure pipe and pipework fittings to be used for the construction of ITER IO Type A Radwaste Treatment and Storage System (Type A radwaste system). The items to be procured under the scope of this LOT are stainless steel pipes and pipework fittings.

### Background

A pipework for Type A Radwaste System is required to transfer the liquid waste or processed liquid

- from Tokamak sump tank to liquid waste holding tank in radwaste building
- from TCWS collection tank to liquid waste holding tank in radwaste building
- from monitor tank to liquid holding tank in tritium plant building.

### Scope of work

- General Requirements

The Contractor shall supply to the ITER IO Type A radwaste system pipe and pipework fittings (tees, elbows, caps, branches etc.) with the following requirements:

- ✓ Pipe: Seamless stainless steel, ASTM A312 Grade TP304, Schedules 40S per ANSI/ASME B36.19M, Sizes DN50.
- ✓ Fittings: Seamless, butt welding fittings per ASME B16.9, ASTM A403 Grade WP304.

- Code & Regulatory Requirements

Pipe and pipework fittings procured under the scope of this LOT shall perform a confinement function<sup>5</sup>.

As defined in the French Order of 7<sup>th</sup> February 2012 establishing the general rules for basic nuclear installations [4] components which perform a safety function (e.g. provide confinement) are classified as Protection Important Components (PIC) and hence shall satisfy the requirements of the said order.

Pipe and pipework fittings shall comply with ASME B31.3-2010 Category M fluid.

---

<sup>5</sup> Confinement is the term used for the physical enclosure of hazardous substances (e.g. ACP and tritium).



Pipe and pipework fittings shall be supplied with material certification in compliance with EN 10204:2004 type 3.2.



## Annex 7

# Technical Summary for LOT 7 (CCWS and CHWS)

### Purpose

The purpose of this LOT is to procure pipe and pipework fittings to be used for the construction of ITER IO Component Cooling Water System (CCWS) and Chilled Water System (CHWS) inside the nuclear and non-nuclear buildings. The items to be procured under the scope of this LOT are stainless steel and carbon steel pipes and pipework fittings.

### Background

Component Cooling System (CCWS) consists of 5 independent cooling loops that ensure cooling of nuclear and non-nuclear clients located in the Tokamak complex and in all the auxiliary buildings of the ITER site.

Chilled Water System (CHWS) consists of 2 independent loops that provide chilled water to the Tokamak complex and all the auxiliary buildings.

A network of pipework is required to interconnect between the active equipment of the CCWS, CHWS, the heat exchangers and their clients located throughout ITER site.

### Scope of work

- General Requirements

The Contractor shall supply to the ITER IO CCWS and CHWS pipe and pipework fittings (tees, elbows, caps, reducers, flanges etc.) and associated supports with the following requirements:

- Stainless Steel Pipe:
  - ✓ Seamless or Welded (depending on diameter; To be defined);
  - ✓ Size DN25 to DN650;
  - ✓ Schedule 40/STD;
  - ✓ Material ASTM A312 TP304L (up to DN250);
  - ✓ Material ASTM A 358 GR304L.CL1 (DN250 and above).
- Carbon Steel Pipe:
  - ✓ Seamless or Welded (depending on diameter; To be defined);
  - ✓ Size DN50 to DN 600;
  - ✓ Schedule 40/STD;
  - ✓ Material ASTM A53 GR.B (for up to DN400);



- ✓ Material ASTM A 672 GR.B 60 (DN400 and above).

The scope of supply includes manufacture, testing, cleaning, packaging and delivery of the pipe and pipework fittings to the ITER site, France, or to a workshop in the vicinity of the site. The majority of the pipework falls into the category of quality class QC2 except for a limited quantity of CCWS pipework and CHWS piping which is quality class QC1.

- Code & Regulatory Requirements

Part of the pipe and pipework fittings procured under the scope of this LOT shall perform a confinement function<sup>6</sup>.

As defined in the French Order of 7<sup>th</sup> February 2012 establishing the general rules for basic nuclear installations [4] components which perform a safety function (e.g. provide confinement) are classified as Protection Important Components (PIC) and hence shall satisfy the requirements of the said order.

Pipe and pipework fittings shall comply with ASME B31.3-2010 Category D fluid.

- Specific Component Cooling and Chilled Water Systems Requirements

Details on the scope of works, the materials to be provided and the scheduling will be clarified at the Call for Tender stage.

---

<sup>6</sup> Confinement is the term used for the physical enclosure of hazardous substances (e.g. tritium).